

IS : 10042 - 1981

Indian Standard

CODE OF PRACTICE FOR
SITE INVESTIGATIONS FOR FOUNDATION
IN GRAVEL-BOULDER DEPOSIT

UDC 624.131.31 : 624.15.051 : 69.032.2 : 006.76



© Copyright 1982

INDIAN STANDARDS INSTITUTION
MANAK BHAVAN, 9 BAHADUR SHAH ZAFAR MARG
NEW DELHI 110002

Price Rs 8.50

April 1982

Indian Standard

CODE OF PRACTICE FOR SITE INVESTIGATIONS FOR FOUNDATION IN GRAVEL-BOULDER DEPOSIT

Soil Engineering and Rock Mechanics Sectional Committee, BDC 23

<i>Chairman</i>	<i>Representing</i>
DR JAGDISH NARAIN	University of Roorkee, Roorkee
 <i>Members</i>	
ADDITIONAL DIRECTOR, IRI	Irrigation Department, Government of Bihar, Patna
ADDITIONAL DIRECTOR RESEARCH (F.E.), RDSO	Ministry of Railways
DEPUTY DIRECTOR RESEARCH (SOIL MECH), RDSO (<i>Alternate</i>)	
SHRI P. D. AGARWAL	Public Works Department, Government of Uttar Pradesh, Lucknow
DR B. L. DHAWAN (<i>Alternate</i>)	
PROF ALAM SINGH	University of Jodhpur, Jodhpur
COL AVTAR SINGH	Engineer-in-Chief's Branch, Army Headquarters
LT-COL V. K. KANITKAR (<i>Alternate</i>)	
CHIEF ENGINEER (D&R)	Irrigation Department, Government of Punjab Chandigarh
DR G. S. DHILLON (<i>Alternate</i>)	
SHRI M. C. DANDAVATE	The Concrete Association of India, Bombay
SHRI N. C. DUGGAL (<i>Alternate</i>)	
SHRI A. G. DASTIDAR	In Personal Capacity (<i>5 Hungerford Street, 12/1, Hungerford Court, Calcutta-700017</i>)
DR G. S. DHILLON	Indian Geotechnical Society, New Delhi
DIRECTOR, IRI	Irrigation Department, Government of Uttar Pradesh, Roorkee
SHRI A. H. DIVANJI	Asia Foundations and Construction (P) Ltd, Bombay
SHRI A. N. JANGLE (<i>Alternate</i>)	
DR GOPAL RANJAN	Institution of Engineers (India), Calcutta
DR GOPAL RANJAN	University of Roorkee, Roorkee
SHRI S. GUPTA	Cemindia Co Ltd, Bombay
SHRI N. V. DE SOUSA (<i>Alternate</i>)	
SHRI G. S. JAIN	G. S. Jain & Associates, Roorkee
SHRI VIJAY K. JAIN (<i>Alternate</i>)	

(*Continued on page 2*)

© Copyright 1982

INDIAN STANDARDS INSTITUTION

This publication is protected under the *Indian Copyright Act (XIV of 1957)* and reproduction in whole or in part by any means except with written permission of the publisher shall be deemed to be an infringement of copyright under the said Act.

(Continued from page 1)

<i>Members</i>	<i>Representing</i>
SHRI A. B. JOSHI DEPUTY DIRECTOR (CSMRS) (<i>Alternate</i>)	Central Water Commission, New Delhi
COL M. V. KAYERKA SHRI V. B. GHORPADE (<i>Alternate</i>)	Ministry of Defence (R&D)
SHRI O. P. MALHOTRA	Public Works Department, Chandigarh Administration, Chandigarh
SHRI D. R. NARAHARI SHRI B. G. RAO (<i>Alternate</i>)	Central Building Research Institute (CSIR), Roorkee
SHRI T. K. NATRAJAN DR G. V. RAO DR K. K. GUPTA (<i>Alternate</i>)	Central Road Research Institute, New Delhi Indian Institute of Technology, New Delhi
RESEARCH OFFICER (B & RRL)	Public Works Department, Government of Punjab, Chandigarh
SHRI K. R. SAXENA	Engineering Research Laboratories, Government of Andhra Pradesh, Hyderabad
SECRETARY DEPUTY SECRETARY (<i>Alternate</i>)	Central Board of Irrigation & Power, New Delhi
SHRI N. SIVAGURU SHRI D. V. SIKKA (<i>Alternate</i>)	Roads Wing (Ministry of Shipping and Transport)
SHRI K. S. SRINIVASAN SHRI SUNIL BERRY (<i>Alternate</i>)	National Buildings Organization, New Delhi
SHRI N. SUBRAMANYAM	Karnataka Engineering Research Station, Krishnarajasagar
SUPERINTENDING ENGINEER (P&DC) EXECUTIVE ENGINEER (SMRD) (<i>Alternate</i>)	Public Works Department, Government of Tamil Nadu, Madras
SHRI G. RAMAN, Director (Civ Engg)	Director General, ISI (<i>Ex-officio Member</i>)

Secretary

SHRI K. M. MATHUR
Deputy Director (Civ Engg), ISI

Site Exploration and Investigation for Foundation
Subcommittee, BDC 23 : 2

SHRI V.S. AGGARVAL SHRI M.P. JAIN (<i>Alternate</i>)	Central Building Research Institute, CSIR, Roorkee
DR ALAM SINGH	University of Jodhpur, Jodhpur
DEPUTY DIRECTOR RESEARCH (PE), RDSO ASSISTANT DIRECTOR RESEARCH (SOIL MECH), RDSO (<i>Alternate</i>)	Ministry of Railways
DIRECTOR (CSMRS) DEPUTY DIRECTOR (CSMRS) (<i>Alternate</i>)	Central Water Commission, New Delhi

(Continued on page 19)

Indian Standard

CODE OF PRACTICE FOR SITE INVESTIGATIONS FOR FOUNDATION IN GRAVEL-BOULDER DEPOSIT

0. FOREWORD

0.1 This Indian Standard was adopted by the Indian Standards Institution on 30 November 1981, after the draft finalized by the Soil Engineering and Rock Mechanics Sectional Committee had been approved by the Civil Engineering Division Council.

0.2 The advent of the large river valley projects in India necessitated the erection of heavy industrial complexes in river or old river courses. It will, therefore, be necessary to determine foundation conditions in respect of the following before a design can be finalized:

- a) Sequence and extent of overburden soil underlain by boulder-gravel soil deposit to be affected by the proposed work;
- b) Nature of matrix of boulders;
- c) The amount and state of packing of the boulders, their nature (rounded or otherwise) and the size of the boulders present;
- d) Whether the boulder-gravel is lying in the matrix of material or otherwise;
- e) Nature of each stratum if there is any change, ground water table and its possible effects on foundation material; and
- f) General information on geology and surface drainage, etc.

This standard has, therefore, been formulated to cover these aspects, as methods adopted for soils (*see IS: 1892-1979**) will not be applicable in such cases.

0.3 In the formulation of this standard, considerable assistance has been given by Central Building Research Institute, Roorkee.

0.4 For the purpose of deciding whether a particular requirement of this standard is complied with, the final value, observed or calculated, expressing the result of a test or analysis, shall be rounded off in accordance with IS : 2-1960†. The number of significant places retained in the rounded off value should be the same as that of the specified value in this standard.

*Code of practice for subsurface investigations for foundations (*first revision*).

†Rules for rounding off numerical values (*revised*).

1. SCOPE

1.1 This code deals with the subsurface investigation in relation to design of foundations for single and multistoreyed buildings, overhead water tanks, piers and abutments of bridges in boulder-gravel deposits.

2. TERMINOLOGY

2.0 For the purpose of this standard, the following definitions in addition to those given in IS : 2809-1972* shall apply.

2.1 **Boulder—Boulder Test (BBT)** — A block cut out of the boulder soil is sheared under a normal load.

2.2 **Concrete — Boulder Test (CBT)** — A cast *in situ* concrete block on boulder soil and pushing the block laterally under a normal load.

2.3 **Depth on Foundation** — The minimum vertical distance between the soil surface and base on the foundation.

2.4 **Dynamic Cone Penetration Test (DCPT)** — A subsurface sounding used to ascertain the soil strata.

2.5 **Residual Shear Strength** — Minimum shear strength exhibited by the soil.

3. SYMBOLS

3.1 For the purpose of this standard and unless defined in the text, the following letter symbols shall have the meaning indicated against each:

B_f = width of the strip foundation, side of square foundation, diameter of circular foundation expressed in metres,

q_a = allowable soil pressure corresponding to 12 mm or 25 mm settlement in tonnes/m²,

τ_o = residual soil strength in tonnes/m²,

S_a = allowable settlement for a structure in cm,

N'' = cumulative number of blows corresponding to a depth D_c in m,

D_c = depth of penetration in cm,

B_c = diameter of cone in cm, and

γ_c = natural unit weight of the soils in tonnes/m³.

*Glossary of terms and symbols relating to soil engineering (*first revision*).

4. GENERAL

4.1 The type of material found in such locations as river beds or old river courses falls neither in the class of soils nor rocks but in the form of gravel-boulders.

The average size of the boulder is larger than 300 mm and it is generally mixed with fine (4.75 — 20 mm) to coarse (20 — 80 mm) gravels. Soils with a large quantity of gravel-boulders deposit pose several problems in investigation. The presence of large sized particles precludes the sampling by the usual methods of soil sampling in the true sense. Tests on disturbed samples are likely to yield unreliable results, as the natural arrangements of the grains and matrix material are never achieved by recompaction. The best results are obtained by properly chosen field tests.

4.2 Nature of the Deposit — The deposits commonly called boulder deposits may be of fluvial or glacial origin. Generally, there exists some filler material which may be sand, silt or clay mixed with fine to coarse gravels.

4.3 Behaviour Under Load — The performance of such deposits under load, a matter of intelligent guess, is generally made on conservative side leading to high cost of foundations. The behaviour of boulder deposits under high loads also depends upon the size and quantity of gravel-boulder and also the nature and amount of the filler material. If the filler material exists only in the interstices of the boulder (*see* Fig. 1A), the behaviour depends upon the state of packing of the boulders, nature (rounded or otherwise) and the size of the boulder; on the other hand if the boulder exists in the matrix of the filler material (*see* Fig. 1B), the behaviour will be governed by the size, quantity and distribution of the boulder in the filler. When the filler material is absent, the load carrying capacity is high and the compressibility is low. When there exists a filler material, there is an initial compression stage followed by low compression stage when the load carrying capacity is high. If the gravel lies in the matrix of the filler material, the behaviour is governed by the nature of the filler material and it is likely to reduce the compressibility. The boulder soil unlike ordinary soil shows certain peculiar characteristics when the boulder proportion is large (> 30 percent); the deposit shows an initial rapid compression followed by a stage where the compression decreases considerably as the boulders take over the load carrying function (*see* Fig. 2). In such cases, it is of advantage to have the allowable load well in excess of the load at which initial compression occurs, thereby reducing deformations at design loads.

However, in the other situations when the boulder-gravel quantity is small (< 30 percent), normal methods of interpretation (IS : 1888-1982*) will be used (*see* Fig. 3, curves A, E and G).

*Method of load tests (*second revision*).

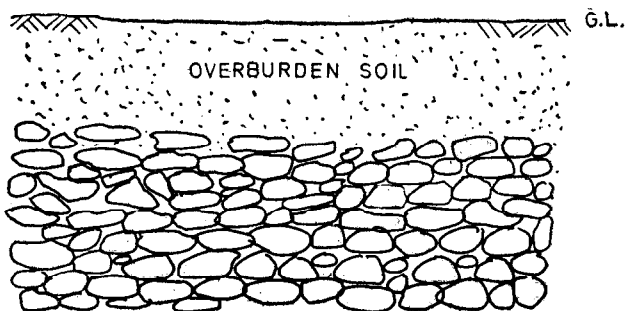

1A FILLER MATERIAL EXISTING IN THE INTERSTICES OF BOULDER/GRAVEL

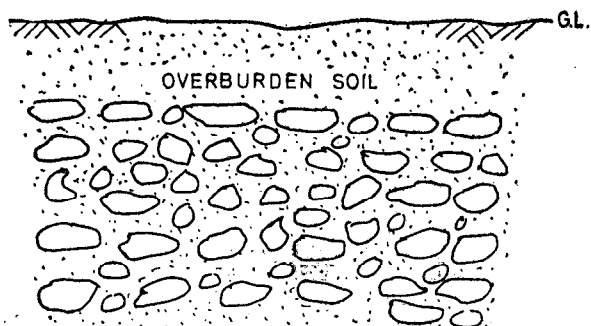

1B BOULDER GRAVEL EXISTING IN THE MATRIX OF THE INTERSTITIAL MATERIAL

FIG. 1 GRAVEL-BOULDER SOIL STRATUM

4.4 Influence of Filler Material — If the cobbles/boulders exist in the matrix of the filler material, properties of the matrix govern the overall behaviour, though the presence of gravel/boulder shall reduce the compressibility of the matrix material to some extent (*see* Fig. 3 and 4). However, if this material exists only in the interstices of the boulders, the boulders being in contact (*see* Fig. 1A), the behaviour is essentially governed by the boulder.

5. METHODS OF INVESTIGATIONS

5.1 Field Test — The method of exploring by open trial pits consists in excavating trial pits at the site and thereby exposing the sub-soil strata thoroughly, enabling identification and classification of the soil. The pit size

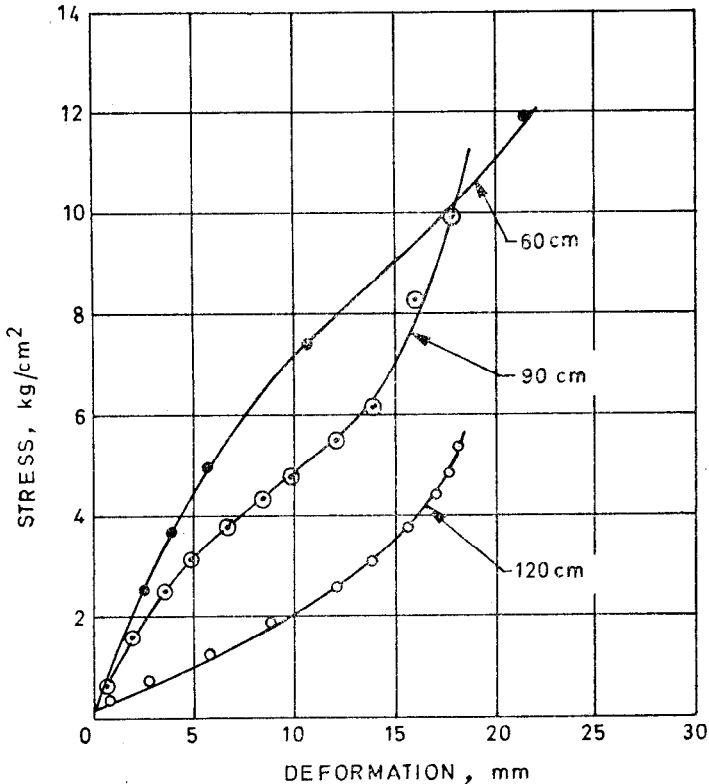

Natural density = 2.21 gm/cc
 Grain > 5 cm = 57%
 Max grain size = 350 mm
 Grain > 12 mm = 32%

FIG. 2 LOAD SETTLEMENT CURVES MATERIAL LIES IN THE MATRIX OF BOULDERS

shall be sufficiently large (5 × 5 m) but not less than 2 × 2 m. The depth of excavation is 4 to 6 m. The sides of the pit shall be sloped or the shored excavation shall be employed to check against any possible slides in case of deep excavation when the depth of the boulder stratum is large (10 to 15 m), with large size of the pit (15 × 15 m). Large pits are necessary when heavy structures are founded on bouldery soils.

5.2 Soil Classification and Sampling — Due to the native nature of the material, the undisturbed sampling is not possible for identification and

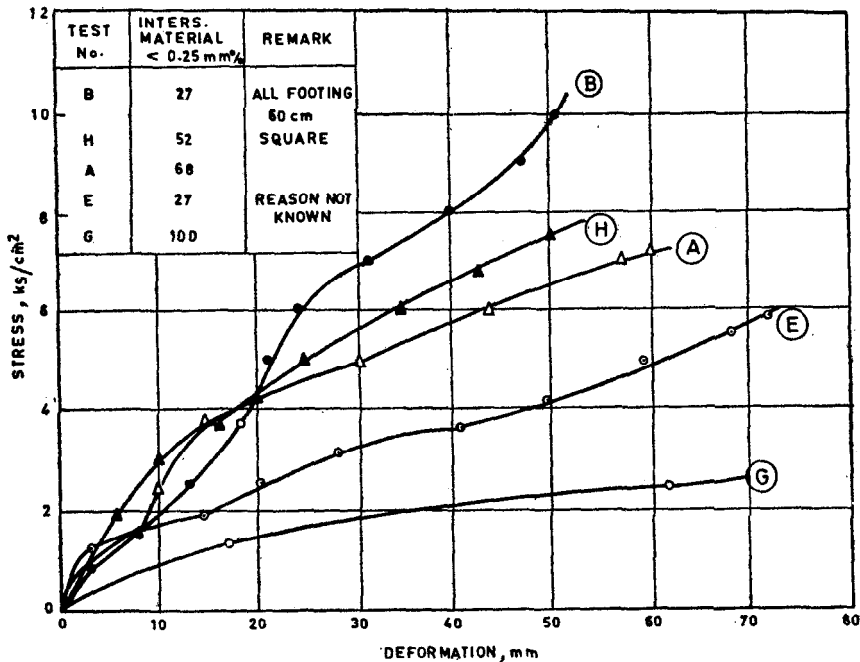

FIG. 3 LOAD SETTLEMENT CURVES (BOULDER LIES IN THE MATRIX OF MATERIAL)

testing purposes. During the course of excavation of the technical pit, disturbed samples shall be collected at about 1 m depth or change of strata for identification and grain size analysis.

NOTE — These samples shall also be used to determine the moisture content of the material and the overall proportion of material in the boulder soil strata.

5.3 In Situ Density — The measurement of natural density shall be made by water replacement method/sand replacement method. For this purpose, a pit of known dimensions is excavated (1 m × 1 m × 50 cm).

The entire excavated soil is carefully collected and weighed with the help of a spring balance (100 kg capacity). The pit is then covered with a polyethylene sheet large enough to touch the sides and the base of the pit. The pit is filled with known volume of water up to the surface of the pit [IS : 2720 (Part XXXIII)-1971*]. The density is calculated from the known mass and volume of the soil. Sometimes dry clean sand may also

*Methods of test for soils: Part XXXIII Determination of the density in-place by the ring and water replacement method.

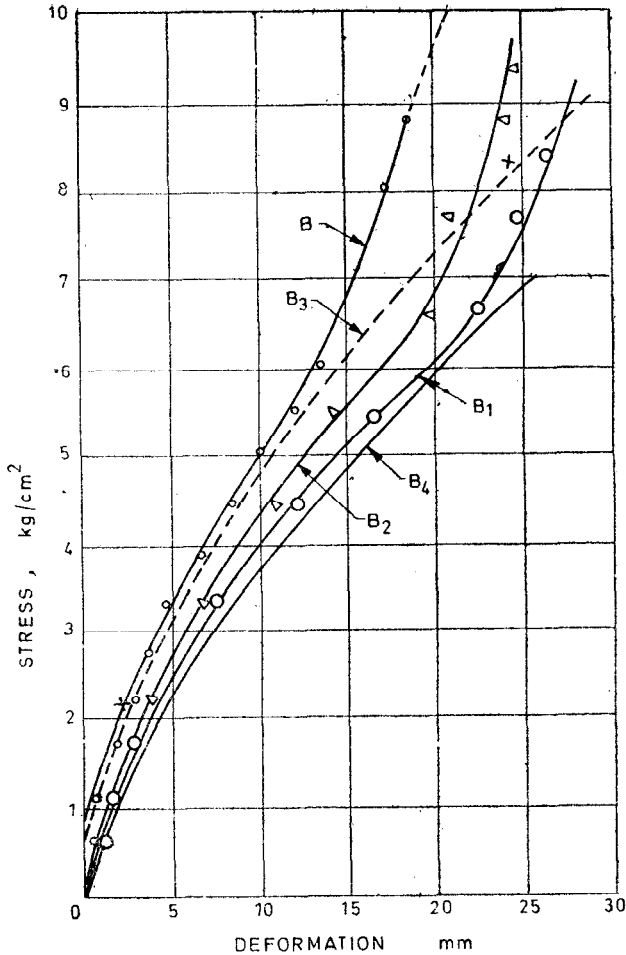

TEST No.	INTERSTITIAL MATERIAL < 5 cm%	REMARKS
B	47	All footings 90 cm ²
B ₁	40	
B ₂	60	
B ₃	57	
B ₄	58	

FIG. 4 INFLUENCE OF INTERSTITIAL MATERIAL ON THE LOAD CARRYING CAPACITY OF BOULDER SOILS

be well adopted to measure the volume of the excavated soil. The collected soil may also be used for grain size analysis and soil classification.

5.4 Dynamic Cone Penetration Test (DCPT) — This test [IS : 4968 (Part I) - 1976*] shall be performed, if the aggregate size is not larger than 100 to 120 mm. The test set-up is similar to that in the standard penetration test, the standard SPT Sampler being replaced by a push fit cast iron cone with 60° apex angle and base diameter 62.5 mm. Use of cone of this size ensure sufficient clearance (11.36 mm) with the standard A drill rod and helps in reducing friction on the rod (see Fig. 5). The cone is driven

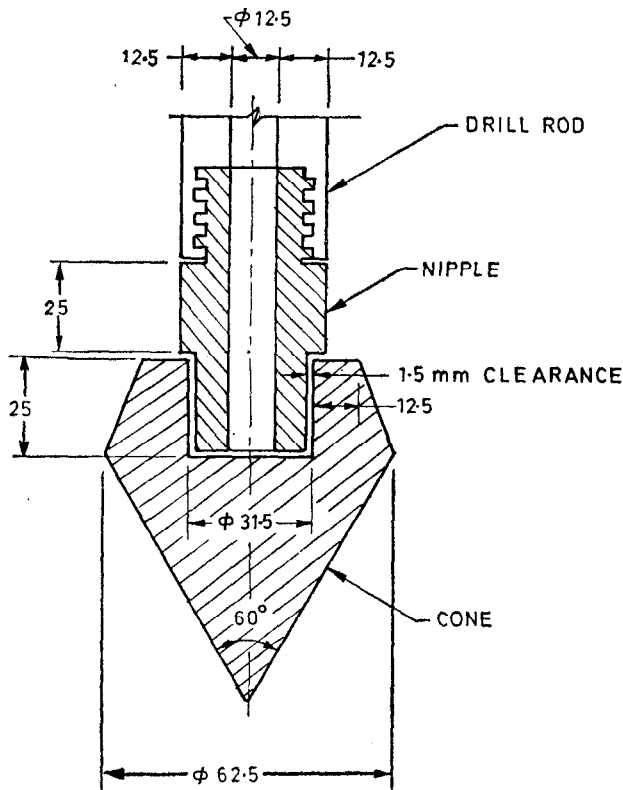

All dimensions in millimetres.

FIG. 5 DIAGRAMMATIC SKETCH OF 62.5 mm DIA CONE

*Method for subsurface sounding for soils: Part I Dynamic method using 50 mm cone without bentonite slurry (first revision).

from the level of the footing with a 65 kg hammer dropping from a height of 750 mm. The number of blows for every 15 cm shall be counted and a plot between cumulative number of blows N'' and D/B_e is prepared. A typical plot is shown in Fig. 6.

NOTE — In order to avoid damage to the equipment, driving may be stopped when the number of blows for the last 30 cm is 100. Assembly of the equipment shall be in accordance with Fig. 2 of IS : 4968 (Part II) - 1976*.

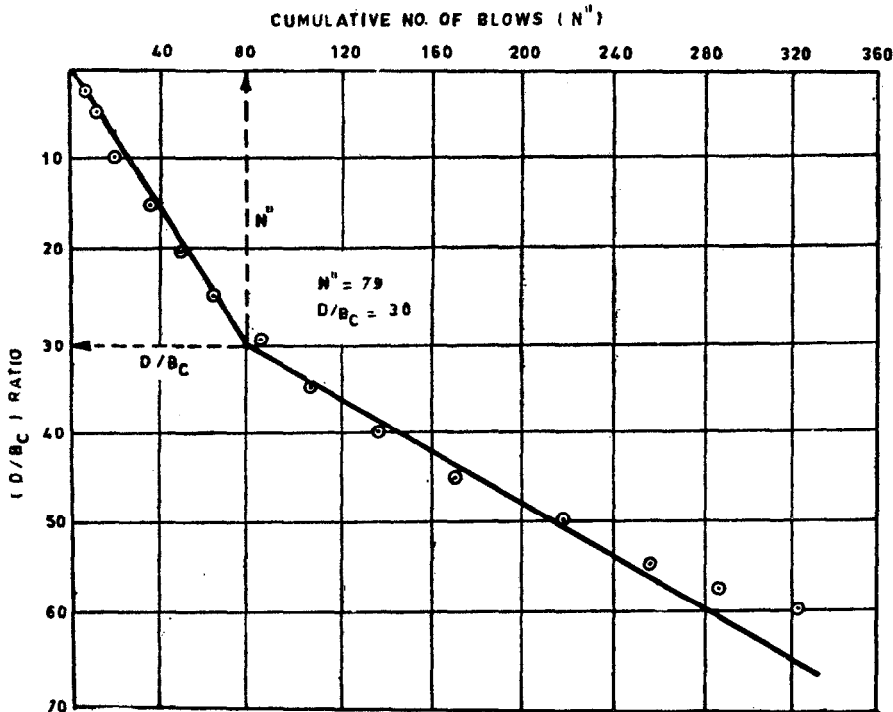

FIG. 6 TYPICAL PLOT OF DEPTH/WIDTH (D/B_e) RATIO AND CUMULATIVE NO. OF BLOWS (N'')

5.5 Load Test on Cast *in-situ* Footing — Considering the large size of aggregates involved, large sized footing need to be used in the test. Steel plates are not of much use because of seating difficulties. Best results are obtained with cast *in-situ* concrete blocks or with precast blocks, set with fresh mortar, so that there is perfect bond between the soil and the block.

*Method for subsurface sounding for soils: Part II Dynamic method using cone and bentonite slurry (first revision).

The size of the footing shall be such that it will span over several boulders so as to mobilize group action under load. To satisfy this criterion, the minimum size of the footing shall not be less than 10 times the average grain size to a minimum of 150 cm.

NOTE — The maximum limit may be increased depending upon feasibility.

The footing shall be loaded using dead load Kentledges platform through a hydraulic jack (100 tonnes capacity). The deformation shall be measured with 4 dial gauges (0.001 mm) in accordance with IS : 1888-1982*. For each increment of load, the deformation shall be noted after intervals of 1, 4, 10, 20, 40 and 60 min and thereafter at hourly intervals. Each load increment shall be kept for not less than 1h or up to a time when the rate of deformation gets reduced appreciably (to a value of 0.02 mm/min). The deformation shall be taken as the average of 4 dial gauges readings. The next increment of load shall then be applied and the observation repeated. The test should be continued till a deformation of 50 mm is reached or till failure occurs, whichever is earlier. A minimum of eight load increments shall be applied to obtain a well defined load settlement curve. Typical graphs are shown in Fig. 2. A typical set is shown in Fig. 7.

If needed, rebound observation may be taken while releasing the load in a similar manner.

5.6 In-Situ Shear Test — The test best suited for such type of deposit to determine strength parameter is *in situ* shear test. It consists in shearing a block of sample under a given normal load. The *in situ* test is a simple form of laboratory shear box test. The interpretation of test results causes difficulties, as identical samples are not likely to be available for many tests under different loads. Two types of tests have been found suitable for such deposits.

5.7 Boulder-Boulder Test (BBT)† — It consists in cutting a block of boulder soil and slowly confining it into a rigid well-designed steel former [IS : 7746-1975‡ and IS : 2720 (Part XXXIX/Sec 1)-1977§]. This soil block is sheared under a normal load. Then the shear (kg/cm^2) is plotted against displacement (mm).

5.8 Concrete-Boulder Test (CBT)† — This test, similar to that recommended in IS : 7746-1975‡ consists in casting a reinforced block and pushing it laterally under a given normal load.

*Method of load tests on soils (second revision).

†The minimum number of tests depends on the area over which the structure has to come and uniformity of strata. However, in the normal case a minimum of two tests are required.

‡Code of practice for *in situ* shear test on rock.

§Methods of tests of soils: Part XXXIX Direct shear test for soils containing gravel, Section 1 Laboratory test.

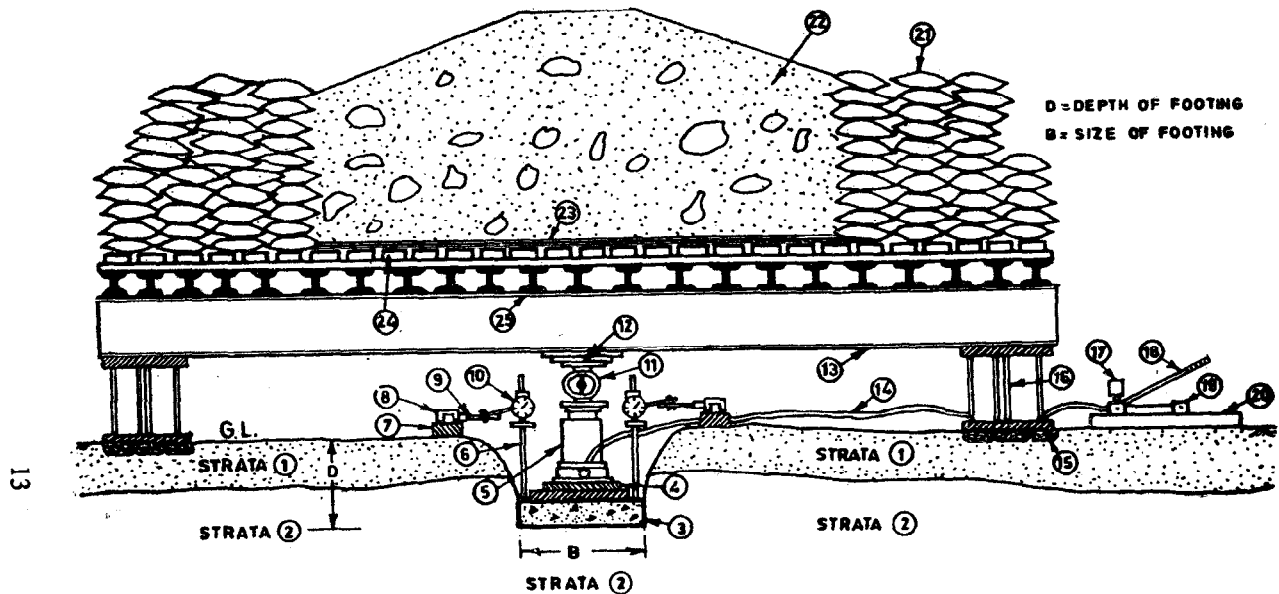

- | | |
|---|---------------------------------------|
| 1. Overburden soil | 13. Main girder |
| 2. Boulder deposit | 14. Flexible pipe |
| 3. Cast <i>in-situ</i> concrete footing | 15. M.S. channel/wooden sleepers |
| 4. M.S. plates | 16. Column |
| 5. Hydraulic jack | 17. Pressure indicator |
| 6. Dial gauge stand | 18. Jack handle |
| 7. Datum bar | 19. Pump for the jack |
| 8. Magnetic base | 20. M.S. plates/wooden sleepers |
| 9. Dial gauge rod | 21. Loading bags |
| 10. Dial gauge | 22. Loading material (excavated soil) |
| 11. Proving ring | 23. M.S. sheets |
| 12. Spacer plates | 24. Sleepers |
| | 25. Girder |

FIG. 7 *In-situ* FULL SIZE FOOTING TEST

For a shear stress, the corresponding displacement is noted and the shear stress (kfg/cm^2) — displacement (mm) curve is plotted. This test has the advantage that it eliminates the need for a steel former and an undisturbed soil block. The concrete blocks used for load test, can also be used for this purpose. Precast concrete blocks may also be used after they are seated with mortar on the foundation bed.

The residual shear stress (τ_0) values obtained from both types of tests (BBT and CBT) are the same. The test set-up for both types of tests and sample results are shown in Fig. 8, 9 and 10.

5.9 Sample Size — In the case of Boulder-Boulder Test (BBT), the minimum size of the sample shall not be less than 10 times the average size of boulders or 120×120 cm, whichever is less. The height of the sample shall, however, be kept at 30 to 45 cm, depending upon the average aggregate size. The minimum size of the concrete block in CBT shall also be 120×120 cm in plan and the thickness may be kept as 30 cm.

NOTE — The size may be increased, depending upon feasibility IS:2720 (Part XXXIX/Sec 2)-1979*.

5.10 Application of Normal Load — The sample in BBT or the concrete block in CBT shall be subjected to a normal load equal to the overburden pressure or the anticipated normal load. The load on the sample may be placed in the form of 20 kg concrete cubes. Alternatively, sand bags of known weights may also be used. However, the intensity of the normal load shall not exceed two times the shear strength of the soil, to avoid a bearing capacity type of failure.

NOTE — For the sample likely to be sheared under high normal loads for the angle of shearing resistance, if considered, the procedure outlined in IS:7746-1975† and IS:2720 (Part XXXIX/Sec 2)-1979* may be followed.

6. ALLOWABLE SOIL PRESSURE

6.1 Load Test — The allowable soil pressure from one or two load tests shall be obtained as outlined in 4.3 and 5.5. These load tests shall be used to confirm results from other large number of less expensive tests such as dynamic cone penetration tests (DCPT) and *in situ* shear tests, (BBT or CBT), particularly when the site under investigation is large.

6.2 Dynamic Cone Penetration Test — The results of dynamic cone penetration test (IS : 4968 (Part I)-1976‡) shall be used to compute allowable

*Methods of test for soils: Part XXXIX Direct shear test for soils containing gravel, Section 2 *In situ* shear test.

†Code of practice for *in situ* shear test on rock.

‡Method for subsurface sounding for soils: Part I Dynamic method using cone and bentonite slurry (*first revision*).

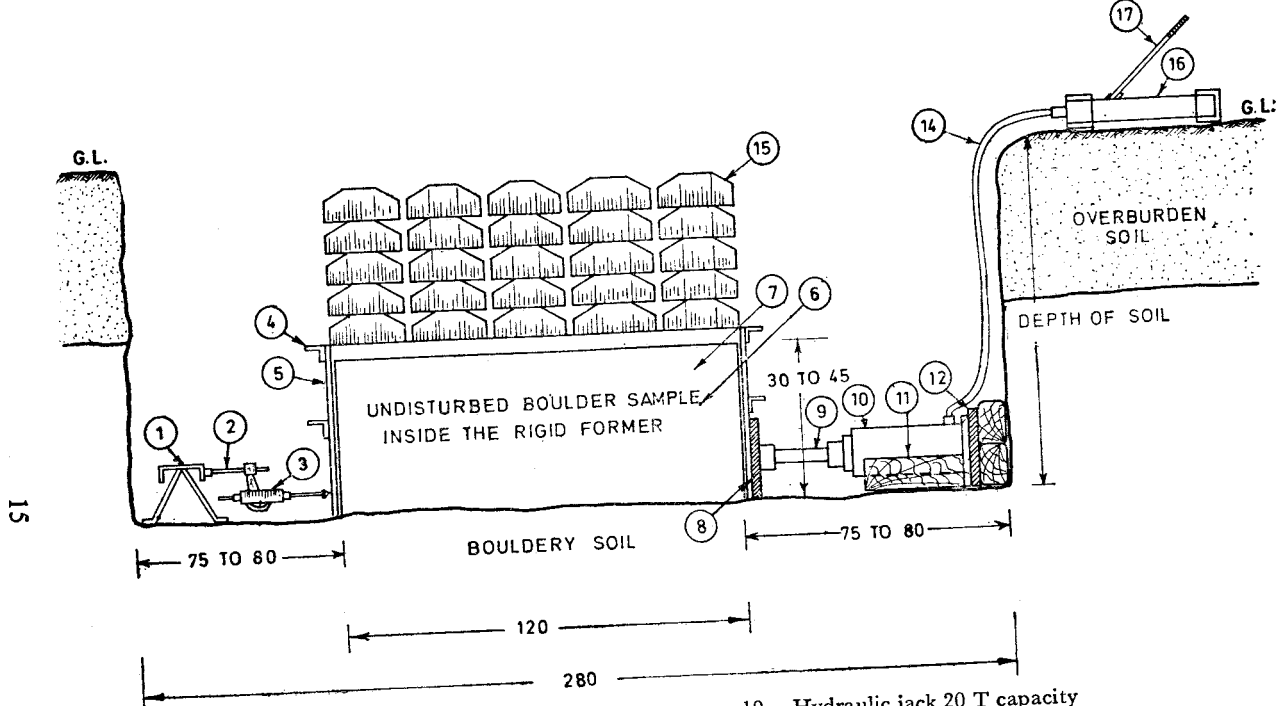

- | | |
|---|---|
| <ol style="list-style-type: none"> 1. Datum bar 2. Magnetic holder 3. Dial gauge 4. Angle iron stiffeners 5. Steel shear box 6. Boulder gravel sample 7. Filler material 8. Steel plates 9. 20 T capacity proving ring | <ol style="list-style-type: none"> 10. Hydraulic jack 20 T capacity 11. Wooden sleeper support for jack 12. Steel plates 13. Wooden sleepers 14. Flexible pipe 15. Steel weights/concrete blocks/sand bag 16. Pump for the jack 17. Handle for the jack |
|---|---|

All dimensions in centimetres.

FIG. 8 TEST SET-UP SHOWING DETAILS OF BOULDER-BOULDER TEST

16

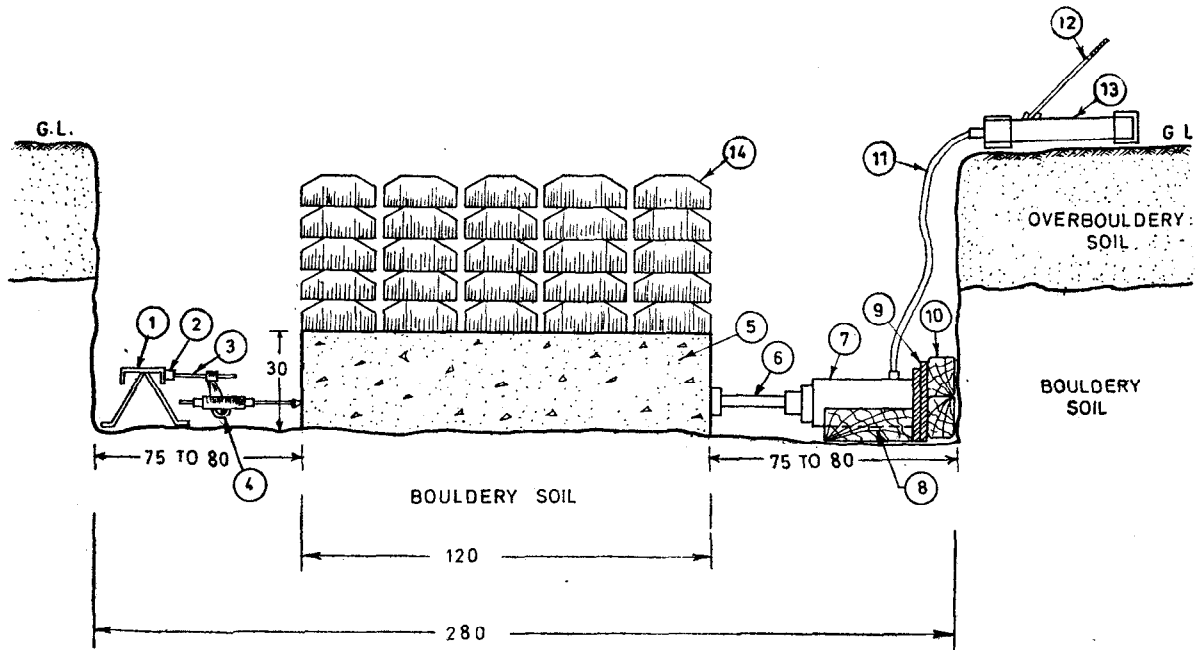

- | | |
|---------------------------------|---|
| 1. Datum bar | 8. Wooden sleeper support for jack |
| 2. Magnetic base | 9. Steel plates |
| 3. Stand for dial gauge | 10. Wooden slipper |
| 4. Dial gauge | 11. Flexible pipe |
| 5. Concrete sample | 12. Handle for jack |
| 6. Proving ring | 13. Pump for jack |
| 7. Hydraulic jack 20 T capacity | 14. Steel weights/concrete blocks/sand bags |

All dimensions in centimetres.

FIG. 9 TEST-SET-UP SHOWING DETAILS OF CONCRETE BOULDER TEST

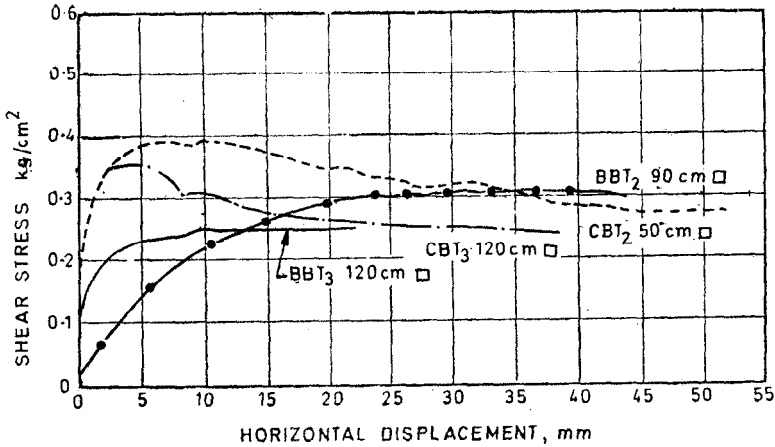

FIG. 10 COMPARISON OF BBT & CBT SHEAR STRESS

pressure (q_a) from the following equation when the maximum grain size is not exceeding 100 mm.

$$q_a = \frac{1}{2.54} \left[\frac{N'' S_a}{D B_f} \right] \dots \dots \dots (1)$$

In Equation (1), the value of allowable deformation S_a (cm) and the footing width B_f (m) shall be assumed in accordance with the type of structure to be constructed. The values of N_c and D shall be taken from Fig. 6.

6.3 In-Situ Shear Tests — The allowable pressure (q_a) shall be computed from the residual shear stress values (ζ) obtained from *in situ* shear tests (BBT or CBT) using the following equation:

$$q_a = (X) \tau_o \left[\frac{B + 0.3}{B} \right]^2 \gamma \dots \dots \dots (2)$$

where

X = constant, 6.25 for a deformation of 12 mm and 8 for a deformation of 25 mm. The value of the width of the footing (B) shall be assumed depending upon the situation and type of structure.

7. LABORATORY TEST

7.1 Soil Sampling — Owing to the nature of the bouldery soil, undisturbed sampling is not possible and hence only disturbed samples from the technical pit shall be collected from different elevations. The quantity of samples

IS : 10042 - 1981

from each depth shall be large enough (1 000 kg) to reflect the actual soil proportions. The material above particle size 80 mm shall be separated and its grading established in the field itself. However, the material below particle size 80 mm shall be collected in suitable containers (gunny bags) and properly labelled immediately, as given in Appendix E of IS : 1892-1979*.

7.2 Grain Size Analysis — The only laboratory test conducted on disturbed samples of bouldery soils is the grain size distribution using appropriate IS sieves to separate boulder/cobbles/gravel (>4.75 mm) and matrix (<4.75 mm).

7.2.1 From the known quantity of the samples collected, and the grain size analysis, the overall proportion of the boulder/gravel shall be collected. This shall be used in deciding if the boulder/gravel lies in the matrix of material or vice versa.

*Code of practice for subsurface investigations for foundations (*first revision*).

(Continued from page 2)

<i>Members</i>	<i>Representing</i>
DIRECTOR, PWDRI	Public Works Department, Government of Uttar Pradesh, Lucknow
EXECUTIVE ENGINEER (DESIGN) V	Central Public Works Department, New Delhi
EXECUTIVE ENGINEER (SMRD)	Public Works Department, Government of Tamil Nadu, Madras
EXECUTIVE ENGINEER (CD) (<i>Alternate</i>)	
SHRI M. D. NAIR	Associated Instruments Manufacturers (India) Private Ltd, New Delhi
PROF T. S. NAGARAJ (<i>Alternate</i>)	
SHRI T. K. NATARAJAN	Central Road Research Institute, New Delhi
LT-COL K. M. S. SAHASI	Engineer-in-Chief's Branch, New Delhi
SHRI A. K. CHATURVEDI (<i>Alternate</i>)	
SHRI S. K. SHOME	Geological Survey of India, Calcutta
SHRI P. N. MEHTA (<i>Alternate</i>)	
SHRI N. SIVAGURU	Roads Wing, Ministry of Transport
SHRI P. K. THOMAS (<i>Alternate</i>)	
SUPERINTENDING ENGINEER (IP), NAGPUR	Irrigation Department, Government of Maharashtra, Bombay

INTERNATIONAL SYSTEM OF UNITS (SI UNITS)

Base Units

<i>Quantity</i>	<i>Unit</i>	<i>Symbol</i>
Length	metre	m
Mass	kilogram	kg
Time	second	s
Electric current	ampere	A
Thermodynamic temperature	kelvin	K
Luminous intensity	candela	cd
Amount of substance	mole	mol

Supplementary Units

<i>Quantity</i>	<i>Unit</i>	<i>Symbol</i>
Plane angle	radian	rad
Solid angle	steradian	sr

Derived Units

<i>Quantity</i>	<i>Unit</i>	<i>Symbol</i>	<i>Definition</i>
Force	newton	N	1 N = 1 kg. m/s ²
Energy	joule	J	1 J = 1 N.m
Power	watt	W	1 W = 1 J/s
Flux	weber	Wb	1 Wb = 1 V.s
Flux density	tesla	T	1 T = 1 Wb/m ²
Frequency	hertz	Hz	1 Hz = 1 c/s (s ⁻¹)
Electric conductance	siemens	S	1 S = 1 A/V
Electromotive force	volt	V	1 V = 1 W/A
Pressure, stress	pascal	Pa	1 Pa = 1 N/m ²